

Mandatory Catalytic Converter
Cod. ACC.077.A1

Optional in Y.066.LDRC
Included in Y.066.KDRC

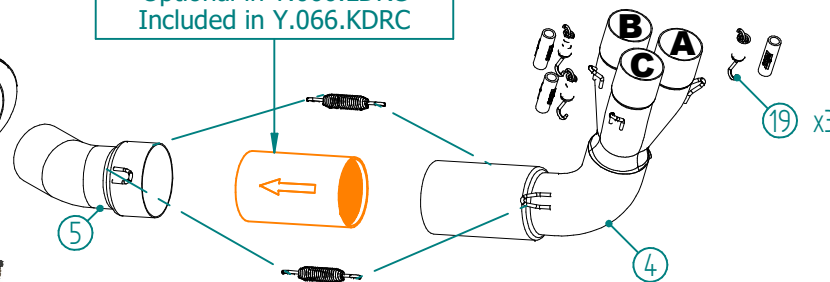

#	DESCRIPTION	PART NUMBER	QTY
1	Collettore #1 / Down pipe #1	9773Y066S2A	1
2	Collettore #2 / Down pipe #2	9773Y066S2B	1
3	Collettore #3 / Down pipe #3	9773Y066S2C	1
4	Tubo di raccordo 3-1 / Link pipe 3-1	9773Y066S2D	1
5	Tubo di raccordo / Link pipe	9773Y066S2EA	1
6	Pre-silenziatore / Pre-silencer	9773Y066S2EB	1
7	Tubo di raccordo / Link pipe	9773Y066S2EC	1
8	Silenziatore / Muffler - dB killer 50.DK.123.0	Delta Race	1
9	Vite M8x20 / Screw M8x20	50.73.894.1	1
10	Rondella in alluminio nera / Black aluminium washer	50.73.221.1	2
11	Staffa / Bracket	50.SS.1278.0	1
12	Rondella di sicurezza / Safety washer	50.73.604.1	2
13	Vite M8 x 16 / Screw M8 x 16	50.73.098.1	2
14	Staffa / Bracket	50.SS.1281.0	1
15	Dado M8 flangiato / Flanged nut M8	50.73.393.1	2
16	Vite M8x40 / Screw M8x40	50.73.075.1	1
17	Molla media / Mid-size spring	50.73.359.1	10
18	Tubo in gomma per molla / Rubber pipe for spring	50.73.210.1	11
19	Molla corta / Short Spring	50.73.123.1	3
20	Boccola interna in acciaio / Internal steel bush	50.73.337.1	3
21	Boccola esterna in acciaio / External steel bush	50.73.338.1	3
22	Flangia in alluminio / Aluminium flange	50.73.339.1	3

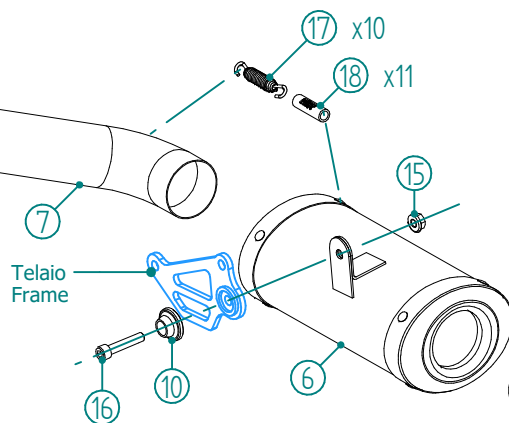

ATTENZIONE: La rimozione del riduttore di rumore è considerata una manomissione dell'impianto di scarico che comporta la perdita dell'omologazione per utilizzo stradale e della garanzia prodotto. In caso di rimozione del riduttore di rumore l'impianto di scarico è in configurazione "racing" e può essere utilizzato solo in pista.

WARNING: Removal of the noise reducer is considered a tampering of the exhaust system which entails the loss of both the type approval for road use and the product warranty. In case of removal of the noise reducer the exhaust system is in "racing" configuration and can be only used on track.

APPLICAZIONI / APPLICATIONS			
CODICE / CODE	NOTE	SILENZIATORE / MUFFLER	TUBO / PIPE
Y.066.LDRC	CATALYTIC CONVERTER NOT INCLUDED	CARBONIO / CARBON FIBER	INOX / ST. STEEL
Y.066.KDRC	CATALYTIC CONVERTER INCLUDED		