

- Rimuovere il supporto del terminale originale. - Remove the support of the original exhaust.
- Parte di telaio su cui fissare la staffetta MIVV. - Frame part where MIVV's bracket shall be fixed.
- Fissaggio terminale MIVV - MIVV's exhaust fixing

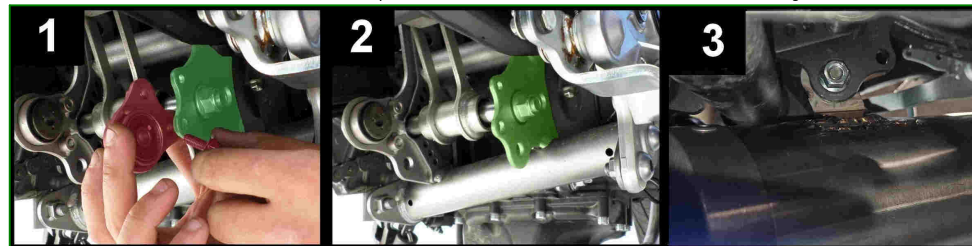

#	DESCRIPTION	PART NUMBER	QTY
1	Collettore #1 / Down pipe #1	9773Y071SRXA	1
2	Collettore #2 / Down pipe #2	9773Y071SRXB	1
3	Tubo di raccordo 2-1 / Link pipe 2-1	9773Y071SRXC	1
4	Tubo di raccordo / Link pipe	9773Y071SRXD	1
5	Pre-silenziatore / Pre-silencer	9773Y071SRXE	1
6	Tubo di raccordo / Link pipe	9773Y071SRXF	1
7	Silenziatore / Muffler db killer 50.DK.141.0	GP PRO 250	1
8	Staffa / Bracket	50.SS.1361.0	1
9	Rondella M6 / Washer M6	50.73.187.1	1
10	Vite M6x16 / Screw M6x16	50.73.087.1	1
11	Vite M8 x 16 / Screw M8 x 16	50.73.098.1	2
12	Rondella di sicurezza / Safety washer	50.73.604.1	2
13	Vite M8x20 / Screw M8x20	50.73.894.1	1
14	Rondella in alluminio / Aluminium washer	50.73.221.1	1
15	Dado M8 flangiato / Flanged nut M8	50.73.393.1	1
16	Molla media / Mid-size spring	50.73.359.1	3
17	Molla corta / Short Spring	50.73.123.1	4
18	Gommino per molla / Rubber for spring	50.73.210.1	7

Pedana originale
Original footrest



cod. 50.73.1015.1

Cavo prolunga sonda lambda
Lambda probe extension cable

Parti originali
Original parts

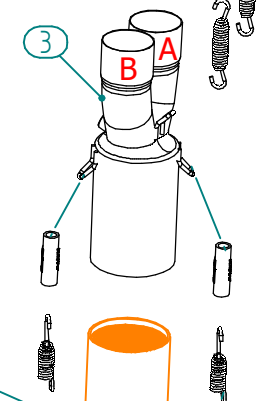
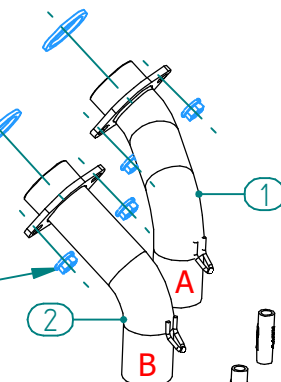

Catalytic Converter
Cod. ACC.077.A1
Optional for Y.071.L2P
Included in Y.071.K2P

OPTIONAL PARTS



ACC.092.0
CARBON COVER

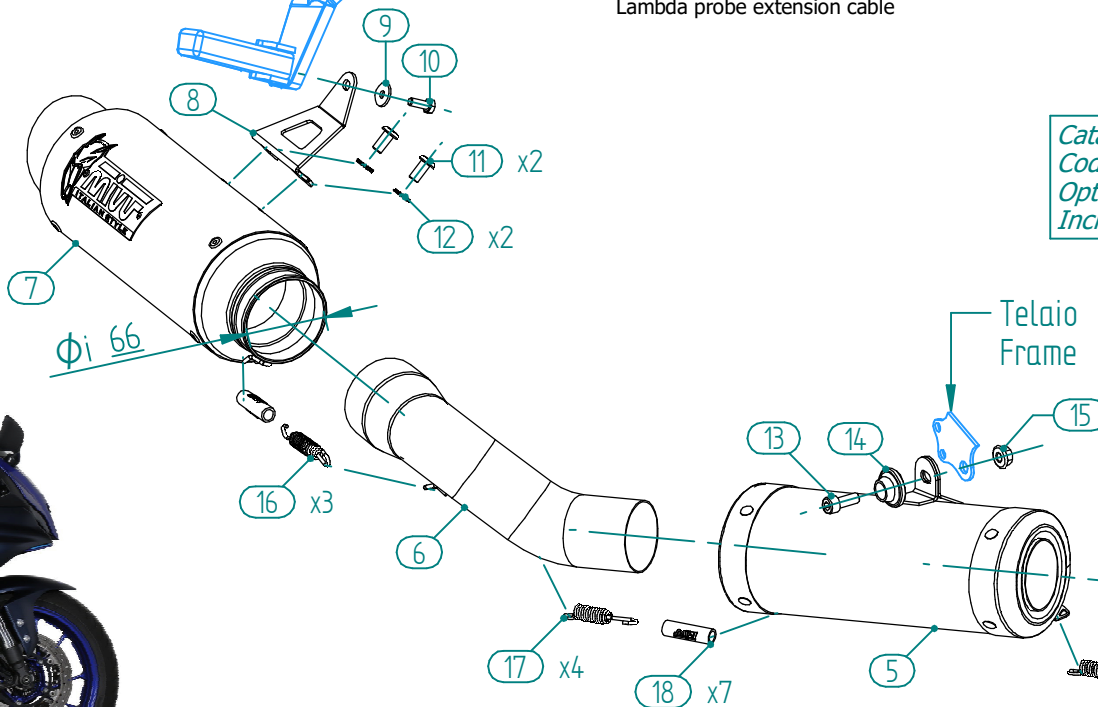

APPLICAZIONI / APPLICATIONS			
CODICE / CODE	NOTE	SILENZIATORE / MUFFLER	TUBO / PIPE
Y.071.L2P	CATALYTIC CONVERTER NOT INCLUDED	CARBONIO / CARBON FIBER	INOX / ST. STEEL
Y.071.K2P	CATALYTIC CONVERTER INCLUDED		

ATTENZIONE: La rimozione del riduttore di rumore è considerata una manomissione dell'impianto di scarico che comporta la perdita dell'omologazione per utilizzo stradale e della garanzia prodotto. In caso di rimozione del riduttore di rumore l'impianto di scarico è in configurazione "racing" e può essere utilizzato solo in pista. La griglia frangifiamma può essere rimontata anche in assenza del riduttore di rumore, tuttavia l'impianto resta in configurazione "racing" e utilizzabile esclusivamente in pista.

WARNING: Removal of the noise reducer is considered a tampering of the exhaust system which entails the loss of both the type approval for road use and the product warranty. In case of removal of the noise reducer the exhaust system is in "racing" configuration and can be only used on track. The flame arrester can be reassembled even without the noise reducer, However, the system remains in "racing" configuration and can be only used on track.